



Why KW2 Technology?

More light, not heat.
Stop melting the talent.

Spectacular images – every day
Color balanced.
10,000 Lamp hours.
No lamp adjustment or replacement for years.

Lower operational cost
Reduced - lamp inventory.
- lamp maintenance.
Lower - power consumption.
- air conditioning bills.

No new power
Refit to existing electrical circuits.

Total control
All Dimming types available in 255 series.

No flicker.

No noise.

ACCENT, dual lamp, mini profile.

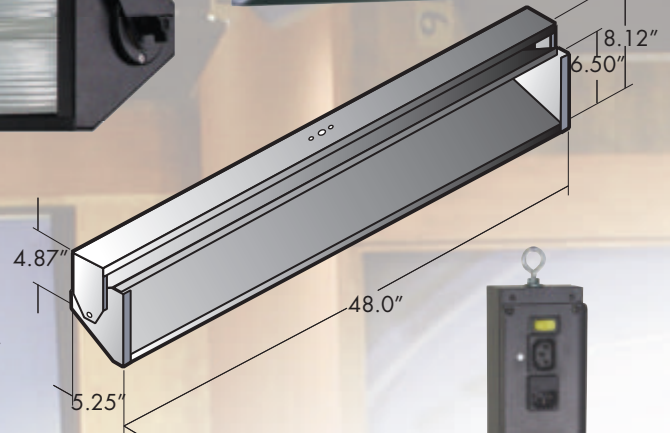

Power Control

FUL Standard	100%
Non dimming	
DIM Line Voltage	10-100%
Power line voltage controls intensity (2 wire dimming)	
DAN Analog	2-100%
Separate 0-10V Circuit controls intensity	
DNR Analog	0-100%
Includes relay shut-off for fade to black, 0-10V	
DMX Digital	0-100%
Fully digital, addressable and daisy chained	
DNR & DMX control housing may be bale or remote mounted	
MSL280 available in FUL (non-dimming) ONLY	



Remote housing may be bale mounted or hung separately



DNR and DMX Controls located in remote housing on MSL2

Available Accessories



Honeycomb



Acrylic Lens



Gelframe



Bare



Wide



Medium



Narrow



214.393.5998
FAX:214.393.5999
www.kw2.com



Manufactured by PL Systems, Inc.
10529 Olympic Drive, Suite #102
Dallas, Texas 75220

REAL SOLUTIONS TO STUDIO LIGHTING

Specifications

Weight	11 lbs., welded aluminum, Global directional adjustment
Sound rating	>Class A
Start temperature	50 degrees F
Lamp type	Fluorescent twin tube, T5 triphosphor
Lamp frequency	25,000 Hz
Power factor	>0.95
Total harmonic distortion	<10%
Transient Protection	EMI Filter FCC Part18C Class A IEEE 587A (ANSI C62.41)
Beam Angle	@ 0 = 100, @ 90 = 50
Field Angle	@ 0 = 134, @ 90 = 90

MSL255

Power consumption	1.0Amps @ 120V,60Hz (110 Watts)
Peak Candlepower	5,700 Candelas
Typical lamp output	2 @ 4,800 = 9,600 Lumens

MSL280

Power consumption	1.5Amps @ 120V,60Hz (180 Watts)
Peak Candlepower	7,000 Candelas
Typical lamp output	2 @ 6,000 = 12,000 Lumens

Ordering Chart

55/830

Studio Lamps, 55W Twin

Catalog ID	Color Temp	CRI	Light output
55/830	3000K	82%	4800L
55/832*	3200K	85%	4000L
55/856*	5600K	85%	4000L
55/930	3000K	98%	3000L
55/950	5000K	98%	3000L
80/830	3000K	82%	6000L

(Two lamps included with each fixture)

* Small upcharge for 832 and 856 lamps

Accessory List

MSL2-45HC-GFC	Honeycomb Wide, black, gelframe
MSL2-25HC-GFC	Honeycomb Medium, black, gelframe
MSL2-17HC-GFC	Honeycomb Narrow, black, gelframe
MSL2-GFC	Gelframe only, black
MSL2-AL	Acrylic lens
2SC	2" Studio C Clamp, short bolts
SCC	Safety cable
25BNC	25ft BNC cable
50BNC	50ft BNC cable

All Fixtures furnished with 12ft power cord
DAN & DNR furnished with 10ft BNC cable



Foot-Candles At Center

Model	140"	65"	36"	23"
MSL255	140	65	36	23
MSL280	175	80	45	30
Distance	6'	9'	12'	15'

MSL255

C

- FUL

120

Fixture Model

MSL255

Single Lamp
MINI accent

MSL280

Color

C Black Housing
T White Housing
Other colors -
Contact factory

Dimming Options

FUL - Full power ballast
DIM - Line voltage dimming
DAN - 0-10V analog dimming
DNR - Fade-to-black, 0-10V dim
DMX - Digital dimming, DMX512

FUL - Full power ballast ONLY

All Fixtures furnished with 12ft power cord
DAN & DNR furnished with 10ft BNC cable

Voltage & Cord Set

120: 120V, 5-15P (3 prong, 'Edison' cord set) Standard
120L5 120V, 5-15L (Twist-Lok, 15A)*
120PG 120V, P&G 3 pin studio plug*
230: 230V 50Hz, 12ft (3) conductor cord, no plug*
277: 277V, 12ft (3) conductor cord, no plug*
No on/off switch on 277V model

*Small upcharge for non-standard voltages or plug sets

Available Models

1SL255
1SL280

MSL255
MSL280

MSL155
MSL180

MSL7

Fill Lights

Portable

Video
Conference



KW/2 PrimeTime
Lighting Systems™

214.393.5998
FAX: 214.393.5999
www.kw2.com

Manufactured by PL Systems, Inc.
10529 Olympic Drive, Suite #102
Dallas, Texas 75220